

油压缓冲器



◎ 订货举例

规格代码	本体外牙	行程	—	1	N
AC: 标准油压缓冲器 AD: 可调式油压缓冲器	08: M8 10: M10 12: M12 16: M16 20: M20	详见规格表		1: 高速 (轻负载) 2: 中速 (中负载) 3: 低速 (重负载)	空白: 塑料防撞帽 N: 无防撞帽

◎ 规格

规格	行程 (mm)	最大吸收能量 (Nm)	小时吸收能量 (Nm/h)	最大有效重量 (kg)			最高撞击速度 (m/s)			工作温度 (°C)
				高速型	中速型	低速型	高速型	中速型	低速型	
AC0404	4	1.2	4300	0.3	1.2	2.5	2	1	0.5	-10~+85
AC0604	4	1.8	6480	0.4	1.8	4	2	1	0.5	-10~+85
AC0805	5	2	6800	0.5	2	6	2	1	0.5	-10~+85
AC0806	6	2.5	7200	0.6	2.5	6.5	2	1	0.5	-10~+85
AC1005	5	3	10800	1	3	7	3	1.5	0.8	-10~+85
AC1008	8	4	14400	2	4	9	3	1.5	0.8	-10~+85
AC1210	10	5	18000	5	10	30	3	1.5	0.8	-10~+85
AC1412	12	15	36000	8	50	100	3	1.5	0.8	-10~+85
AC1416	16	20	40000	10	70	150	3	1.5	0.8	-10~+85
AC1425	25	25	48000	12	80	160	3	1.5	0.8	-10~+85
AC2020	20	40	48000	30	200	700	3.5	2	1	-10~+85
AC2030	30	50	54000	30	200	700	3.5	2	1	-10~+85
AC2050	50	60	66000	60	400	1200	3.5	2	1	-10~+85
AC2525	25	80	60000	200	600	1000	4	2.5	1	-10~+85
AC2540	40	120	84000	300	800	1200	4	2.5	1	-10~+85
AC3660	60	250	125000	400	1500	2400	4	2.5	1	-10~+85
AC2550	50	98	98000	15	40	150	4	2.5	1	-10~+85
AC2580	80	150	127500	20	50	200	4	2.5	1	-10~+85

◎ 外形尺寸图

AC0404/AC0604/AC0805/AC0806/AC1005/AC1008/AC1210

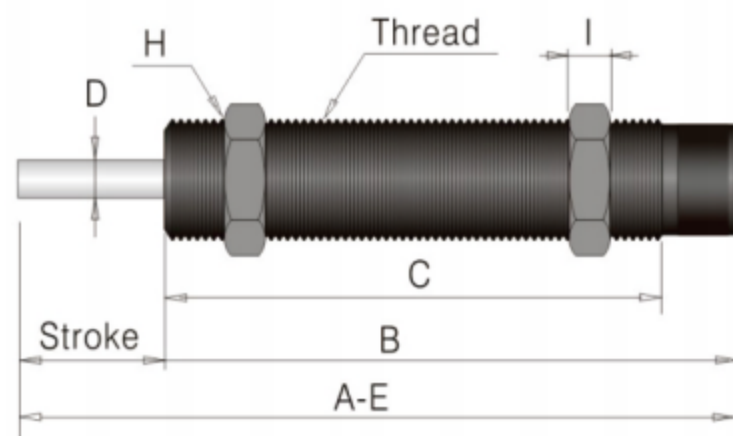

(无撞击头)
without cap

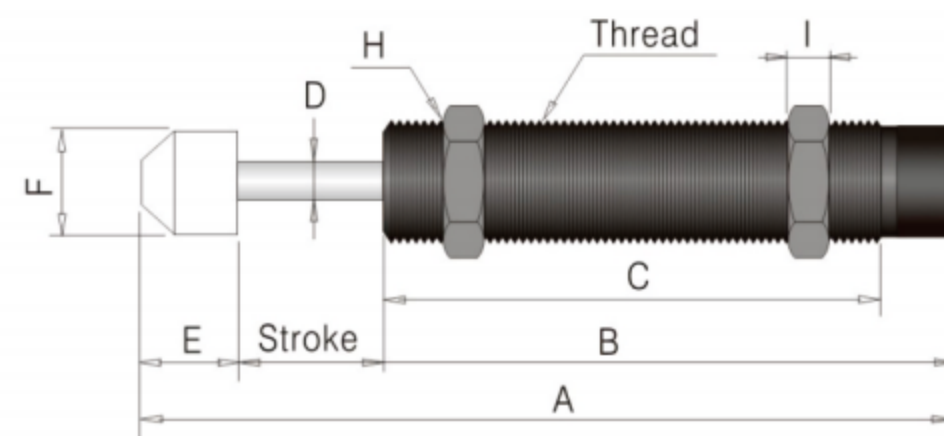

(有撞击头)
with cap

外形尺寸图

AC1412/AC1416/AC1425/AC2020/AC2030/AC2050

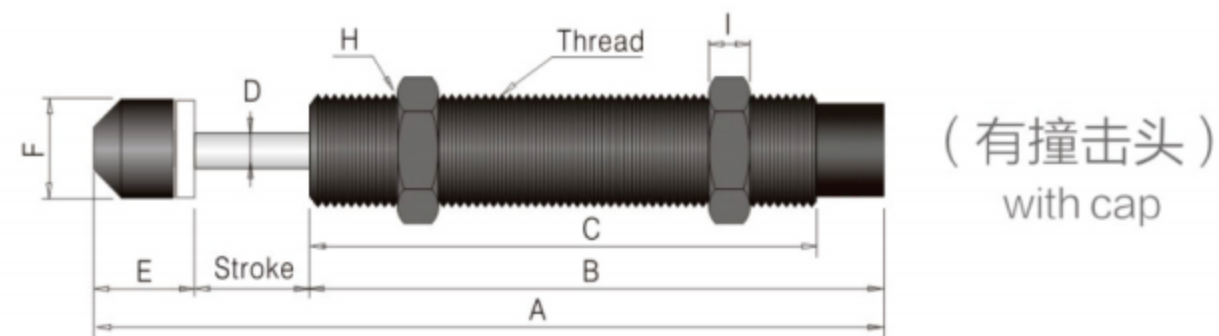
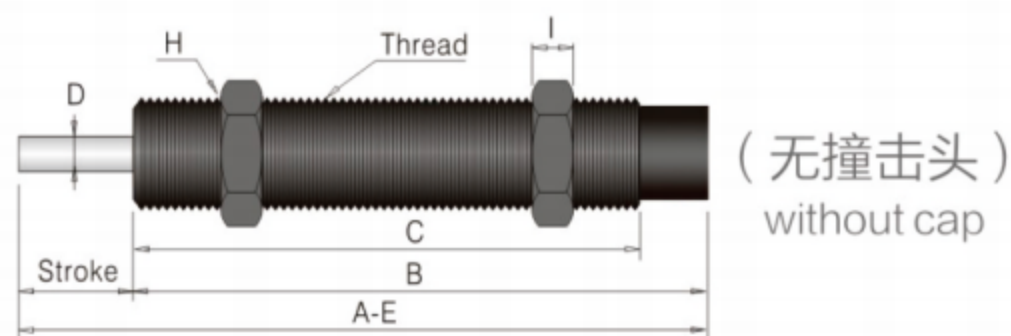

AC2525

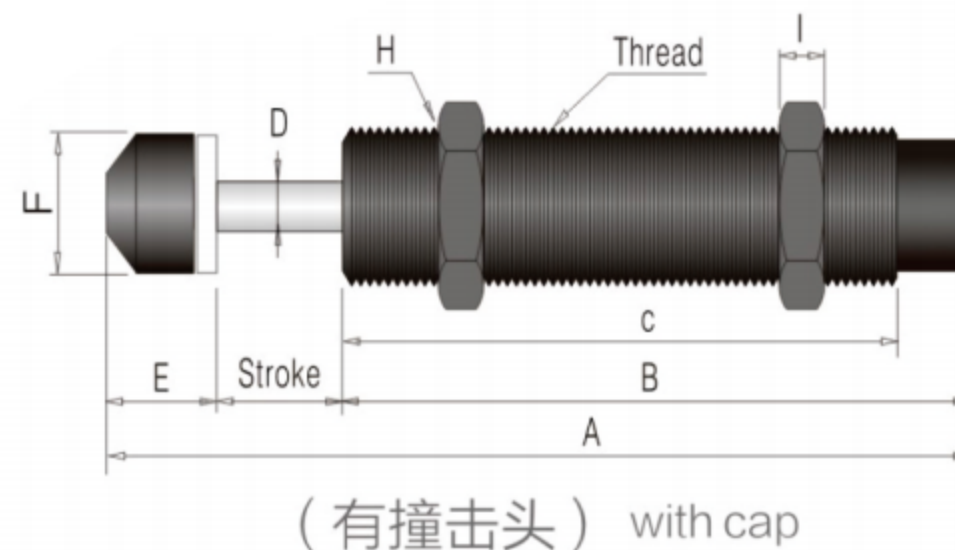
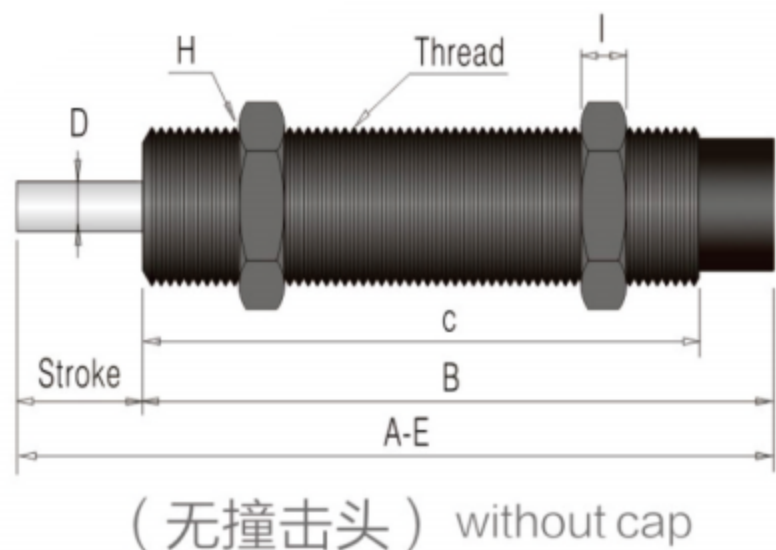

AC2540/AC3660

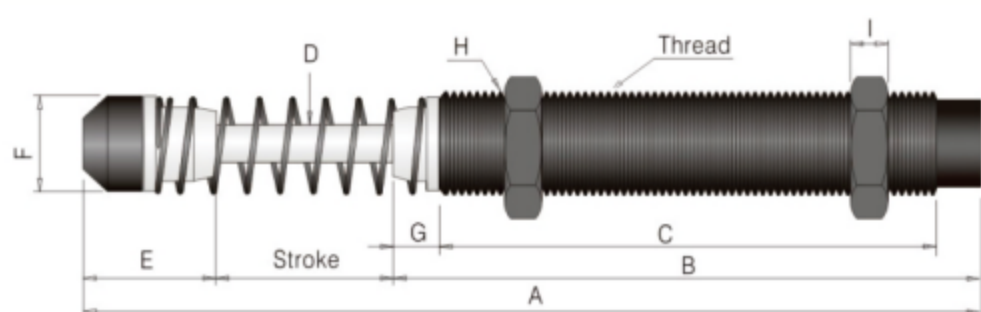

AC2550/AC2580

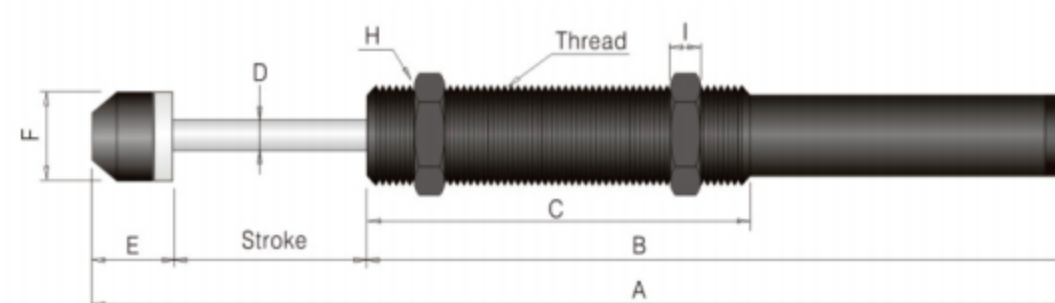

规格	螺纹公称	A	B	C	D	E	F	G	H	I
AC0404	M4 × 0.5	32.6	24.6	19.6	1.2	4	3	-	7	3
AC0604	M6 × 0.75	33.7	25.7	20.6	1.8	4	4.6	-	8	3.3
AC0805	M8 × 0.75	37.9	26.9	21.4	1.8	6	4.6	-	11	4
AC0806	M8 × 1.0	50	38	33	2.9	6	6.6	-	11	4
AC1005	M10 × 1.0	38.7	27.7	22.9	3	6	8.6	-	12.7	4
AC1008	M10 × 1.0	57	43	36.5	3	6	8.6	-	12.7	4
AC1210	M12 × 1.0	69.2	50	45.5	3	9.2	10.3	-	14	4
AC1412	M14 × 1.5	104.2	76.2	70.2	4	12	12	-	19	5
AC1416	M14 × 1.5	123	95	89	4	12	12	-	19	5
AC1425	M14 × 1.5	147	110	104	4	12	12	-	19	5
AC2020	M20 × 1.5	145.8	110	104	6	15.8	18	-	26	8
AC2030	M20 × 1.5	155.8	110	104	6	15.8	18	-	26	8
AC2050	M20 × 1.5	232.8	167	161	6	15.8	18	-	26	8
AC2525	M25 × 1.5	154.5	111	106	8	18.5	22	-	32	10
AC2540	M25 × 1.5	214	137	117	8	37	22	10	32	10
AC2550	M25 × 1.5	239	170.5	100	8	18.5	22	-	32	10
AC2580	M25 × 1.5	335.5	237	100	8	18.5	22	-	32	10
AC3660	M36 × 1.5	247	162	134	10	25	35	17	46	15

1

气动控制元件

2

流体控制元件

3

电气控制元件

4

气动执行元件

5

气源处理元件

6

真空元件

7

洁净元件

8

高真空元件

9

气动辅助元件

◎ 外形尺寸图

AD1410/AD2016/AD2025

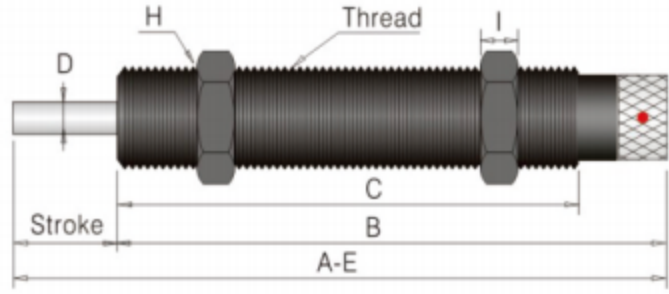

(无撞击头)
without cap

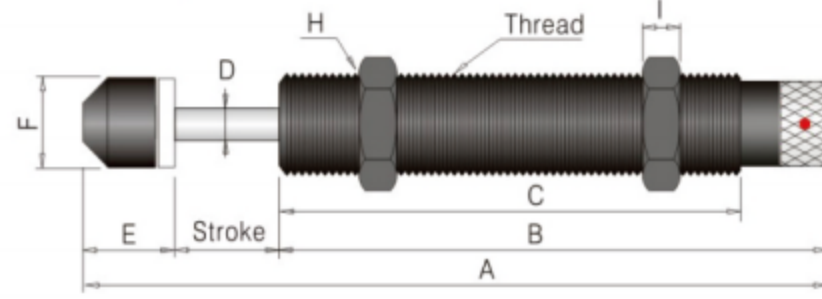

(有撞击头)
with cap

AD2525/AD2530

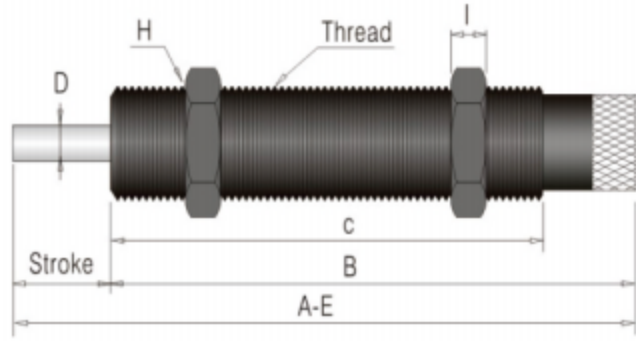

(无撞击头) without cap

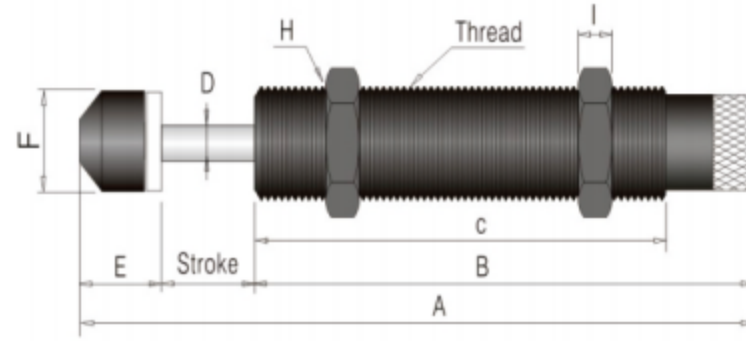

(有撞击头) with cap

AD2540

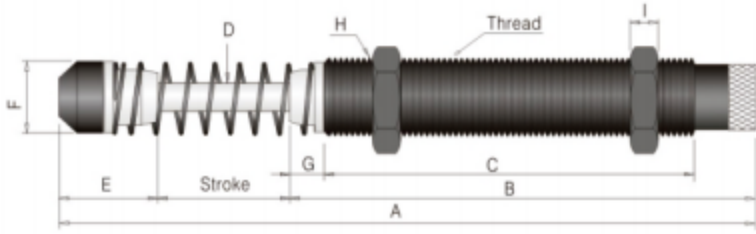

AD3625/3650

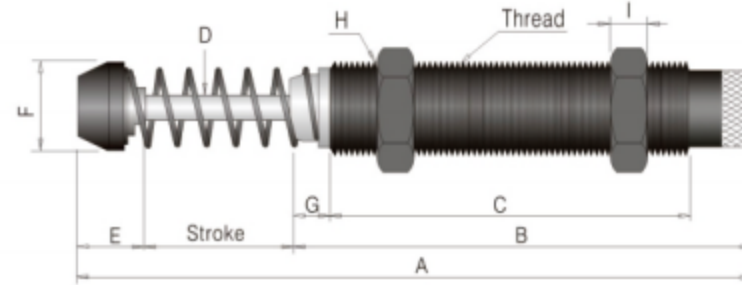

规格	行程 (mm)	最大吸收能量(Nm)	小时吸收能量(Nm/h)	最大有效重量(kg)	最高撞击速度(m/s)	工作温度(°C)
AD1410	10	20	24000	80	3.2	-10~+85
AD2016	16	25	32000	200	3.6	-10~+85
AD2025	25	39	39000	312	3.6	-10~+85
AD2525	25	85	51000	400	3.6	-10~+85
AD2530	30	95	57000	480	3.6	-10~+85
AD2540	40	100	84000	700	3.6	-10~+85
AD3625	25	150	90000	1200	3.2	-10~+85
AD3650	50	300	108000	1400	3.2	-10~+85
AD4225	25	260	130000	3000	3.6	-10~+85
AD4250	50	500	155000	4000	4.8	-10~+85
AD4275	70	750	187000	6000	4.8	-10~+85
AD64050	50	1200	156000	12727	3.5	-10~+85
AD64100	100	2400	192000	18181	3.5	-10~+85
AD64150	150	3600	252000	23636	3.5	-10~+85

外形尺寸图

AD4225/AD4250/AD4275

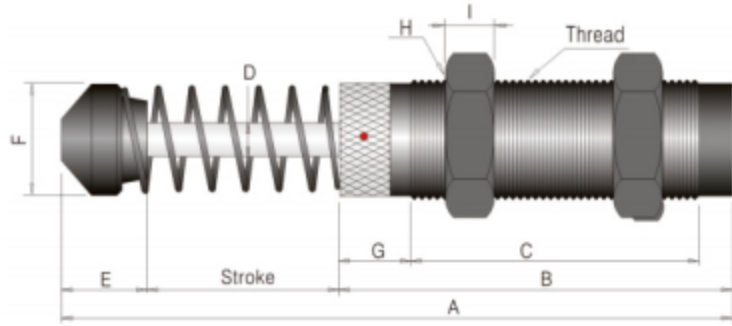

AD64050/AD64100/AD64150

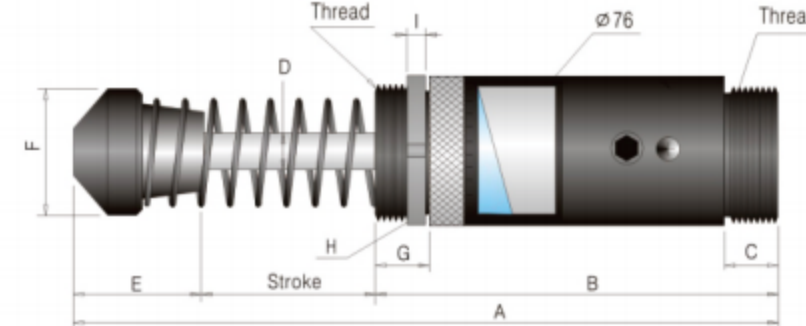

规格	螺纹公称	A	B	C	D	E	F	F	H	I
AD1410	M14 × 1.5	105.2	83.2	70.2	4	12	12	-	19	5
AD2016	M20 × 1.5	148.8	117	101	6	15.8	18	-	26	8
AD2025	M20 × 1.5	157.8	117	101	6	15.8	18	-	26	8
AD2525	M25 × 1.5	162	118.5	101	8	18.5	22	-	32	10
AD2530	M25 × 1.5	167	118.5	101	8	18.5	22	-	32	10
AD2540	M25 × 1.5	221.5	144.5	117	8	37	22	10	32	10
AD3625	M36 × 1.5	183	133	103	10	25	35.5	10	46	15
AD3650	M36 × 1.5	246	171	134	10	25	35.5	17	46	15
AD4225	M42 × 1.5	186	127.5	88	12	33.5	44.5	28.5	50	15
AD4250	M42 × 1.5	245.5	157	117.5	12	38.5	44.5	28.5	50	15
AD4275	M42 × 1.5	301	187.5	148	12	38.5	44.5	28.5	50	15
AD64050	UNF21/2-12	247	146	26	20	51	59	23	76.2	9.4
AD64100	UNF21/2-12	347	196	26	20	51	59	23	76.2	9.4
AD64150	UNF21/2-12	467	256	26	20	61	59	23	76.2	9.4

1

气动控制元件

2

流体控制元件

3

电气控制元件

4

气动执行元件

5

气源处理元件

6

真空元件

7

洁净元件

8

高真空元件

9

气动辅助元件

◎ 偏心角度转换器

型号	行程	A	B	C	D	E	F	G	H
SCL1410	10	34	18	10	8	M14×1.5	M14×1.5	19	17
SCL1415	15	39	23	10	8	M14×1.5	M14×1.5	19	17
SCL2016	16	48	30.5	12	12	M20×1.5	M20×1.5	25	22
SCL2020	20	51	33.5	12	12	M20×1.5	M20×1.5	25	22
SCL2525	25	62	40	14	16	M25×1.5	M25×1.5	35	31
SCL2725	25	62	40	14	16	M27×1.5	M27×1.5	35	31
SCL3325	25	69	47	15	20	M33×1.5	M33×1.5	45	40
SCL3625	25	69	47	15	20	M36×1.5	M36×1.5	45	40

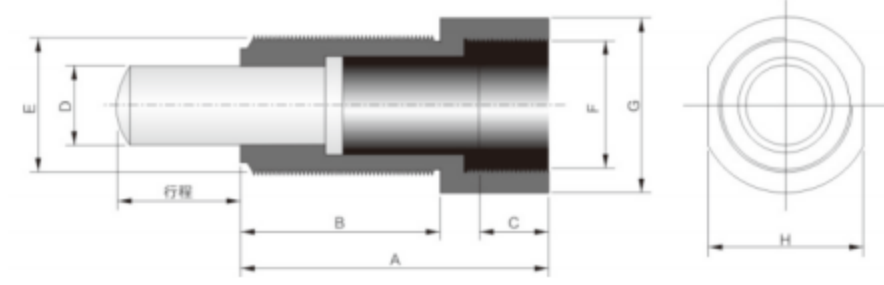

◎ 定位停止螺帽

型号	尺寸	可配合缓冲器规格	型号	尺寸	可配合缓冲器规格
SC08		AC0806	SC20		AC2020 AD2016 AC2030 AD2020 AC2050 AD2025
SC10		AC1005 AC1008	SC25		AC2525 AD2525 AC2550 AD2530 AC2580
SC12		AC1210	SC40		AC2540 AD2540
SC14		AC1412 AD1410 AC1416 AD1425 AC1420 AC1425	SC50		AC3660 AD3625 AD3650

◎ 安装法兰

型号	尺寸	可配合缓冲器规格	型号	尺寸	可配合缓冲器规格
F36		AC3660	F64		AD64050 AD64100 AD64150
F42		AD4225 AD4250 AD4275			

1

气动控制元件

2

流体控制元件

3

电气控制元件

4

气动执行元件

5

气源处理元件

6

真空元件

7

洁净元件

8

高真空元件

9

气动辅助元件